



# Q3 2018

INTERIM REPORT

1 July - 30 September 2018

 FLEXQUBE®

Transforming intralogistics



# THIS IS FLEXQUBE

*FlexQube is a global provider of flexible and robust industrial carts for material handling. The Group was founded in 2010 and in a short period of time has secured a large number of prominent companies as customers.*

Standardized interfaces and modular building blocks allow for a unique, efficient and scalable design process where customers have access to customized cart solutions.

With the aid of configurable carts, material presentation and transport streamline material flows, reduce forklift accidents and improve ergonomics and the work environment.

Currently, FlexQube's sales organization focuses on Europe and North America with manufacturing in Sweden for the European market and in Georgia, USA for the North American market.

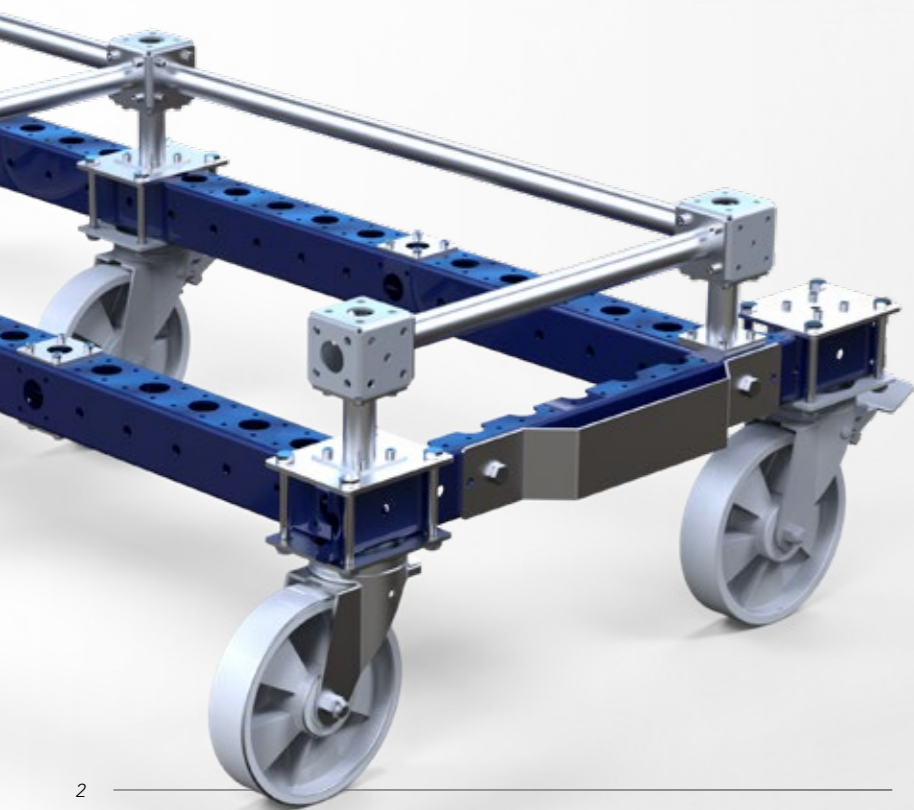

*If you loved to play with Lego® or Meccano® as a child, and as an adult strive for effective internal logistics, you will love this.*

**Per Augustsson**  
 Inventor, co-founder and Technical Manager at FlexQube®

- 2010 FlexQube is started by Anders, Christian and Per in December 2010
- 2011 The patent is granted
- 2012 Sales launch
- 2013 FlexQube Inc. is launched
- 2014 "Made in USA"
- 2015/16 Ranked on the "33-listan" (top 33 most innovative companies in Sweden) two years in a row and new logotype
- 2017 Sales to 22 countries and listing on the Nasdaq First North



- 2018 Sales to a total of 25 countries and strong growth, FlexQube GmbH launched
- 2020 #1 Global supplier of material handling carts



# INTERIM REPORT

1 July - 30 September 2018

- Orders increased by 158 percent to 14.4 MSEK (Million Swedish kronor) (5.6). Adjusted for the impact of currency rates between comparative periods, orders increased by 131 percent.
- Net sales increased by 229 percent to 20.4 MSEK (6.2). Adjusted for the impact of currency rates between comparative periods, net sales increased by 203 percent.
- Earnings before interest, taxes, depreciation and amortization (EBITDA) amounted to -0.1 MSEK (0.2) and earnings before interest and tax (EBIT) amounted to -0.2 MSEK (0.0).
- Revenue before tax amounted to -0.3 MSEK (0.0).
- Cash flow amounted to -8.6 MSEK (-0.3), of which -8.5 MSEK (-0.7) came from operating activities, -0.6 MSEK (-0.1) from investment activities and 0.5 MSEK (0.6) from financing activities.
- Cash and cash equivalents amounted to 12.0 MSEK (0.8) at the end of the period.
- The product development project "FlexQube 4.0" is going according to the development plan and a number of test series carts have been assembled for the purpose of testing in real customer case studies. The patent application for the "platooning" technology, also called virtual linking, has been submitted.
- The refurbishment of the North American unit FlexQube Inc's warehouse, assembly and distribution premises was started in Georgia, USA. The refurbishment will be complete before the end of the year and is expected to increase both productivity and efficiency as well as make it better equipped for handling even larger volumes.
- The first volumes from the roll forming production have emerged on the market with good results and the company is looking forward to increasing production and including these FlexBeams™ in as many solutions as possible.
- The company held a successful strategy week in Sweden with all employees in the Group in mid-August.



1 January - 30 September 2018

- Orders increased by 156 percent to 50.9 MSEK (19.9). Adjusted for the impact of currency rates between comparative periods, orders increased by 149 percent.
- Net sales increased by 137 percent to 53.5 MSEK (22.5). Adjusted for the impact of currency rates between comparative periods, net sales increased by 138 percent.
- Earnings before interest, taxes, depreciation and amortization (EBITDA) amounted to -4.2 MSEK (-0.8) and earnings before interest and tax (EBIT) amounted to -4.7 MSEK (-1.1).
- Revenue before tax amounted to -4.8 MSEK (-1.2).
- Cash flow amounted to -22.1 MSEK (0.7), of which -21.7 MSEK (0.9) came from operating activities, -2.0 MSEK (-0.4) from investment activities and 1.6 MSEK (0.2) from financing activities.
- Cash and cash equivalents amounted to 12.0 MSEK (0.8) at the end of the period.

## Events following the end of the quarter

- FlexQube participated in Volkswagen Innovation Scouting in Hanover, Germany and at Magna Logistics Days in Austria at the start of October.

Sales growth

Order intake increase

+229% +158%



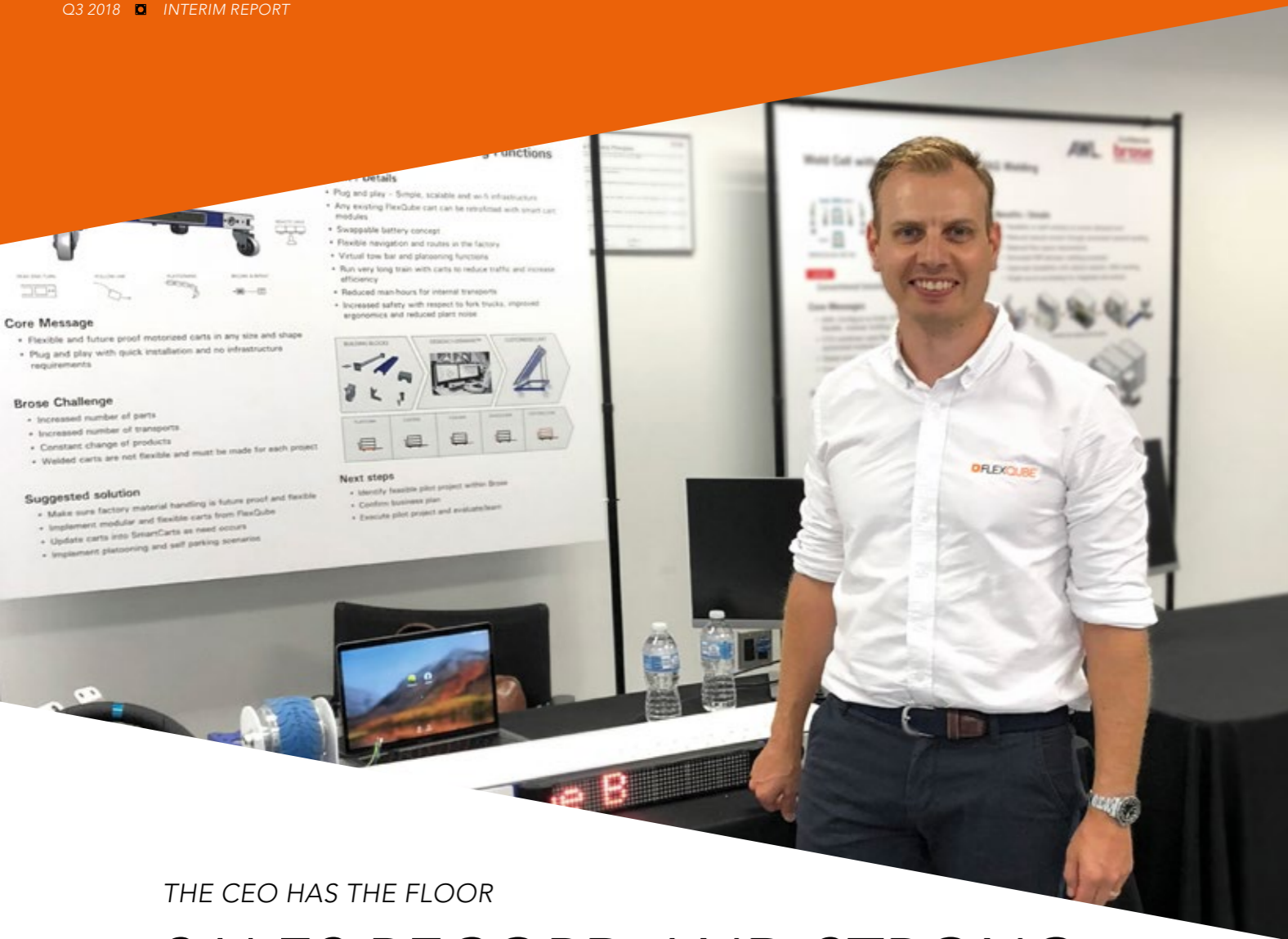

THE CEO HAS THE FLOOR

## SALES RECORD AND STRONG GROWTH IN ORDERS

*Historically, the third quarter has been our weakest as the activity of our customers dips during the summer months. This year we managed to keep the positive trend going from the first half of the year with strong order growth, not least driven by a market that continued to be very strong in the USA. Furthermore, sales climbed to a new record level. Orders increased by 158 percent and sales increased by a record 229 percent compared to the same quarter in 2017.*

With our new FlexBeam™ manufacturing method, we have greater capacity to meet strong growth head on in the future. In addition we see the potential of being able to sell components in crude lengths to customers who want to build their solutions themselves.

During the quarter we have also improved our delivery capacity in North America, which can partly be seen in the sales volumes we are actually achieving. This is about making processes more efficient, reaching new agreements with our most important suppliers for distribution and assembly as well as improving procedures for planning and managing materials.

During the quarter our gross margins increased as a result of boosted economies of scale through higher sales volumes. Also having a positive impact are the cost-reduction projects we have carried out, including the adjusted FlexBeam™ manufacturing method and the efficiency program that was implemented with our main supplier in North America. We see that our gross margin will continue to develop positively going forward and, we are working on several fronts to continually improve it.

Although cash flow fell during the period, it has developed as planned with regards to the growth in inventories and accounts receivable, though they lacked proper financing, as well as to planned investments. It can be noted that the accounts receivable and inventories increased in total by over 13 MSEK during the period, in which financing of outstanding accounts receivable, as of 30 September, would have meant a positive impact on cash flow of around 18 MSEK. We are experiencing higher growth than we expected at the start of 2018 and with the current rate of growth, we expect that the financing of accounts receivable will start being utilized in the beginning of 2019. In addition, we have appointed Carnegie Investment Bank AB, as our financial advisor, to develop an

appropriate future capital structure. We are also exploring new local customer finance solutions in North America.

We envision a broadening of our concept and expect it to appeal to a growing number of industries. During the quarter we have taken on Ben & Jerry's (ice-cream makers) and Wayfair (furniture distribution) as customers.

Our focus on making Germany our largest market in Europe is in full motion. We are seeing positive development for our concept as seen in an increased number of inquiries. Our ambition is to continually strengthen the organization in the future.



Sales grew by  
a record 229%



In August we brought together the entire company to plan our joint strategy, meeting in Sweden. It was a successful week in which we focused on building a strong corporate culture, developing joint goals and creating an organizational structure suited to much higher volumes.

During the fourth quarter, we are planning the first critical customer pilots of our electric carts, which will open up new areas of application for FlexQube. The product, which goes under the working name "FlexQube SmartCart™", has been developed with flexibility and simplicity in mind. The hardware platform is inspired mainly by the consumer and car industries. "Digital" building blocks, such as motors, batteries

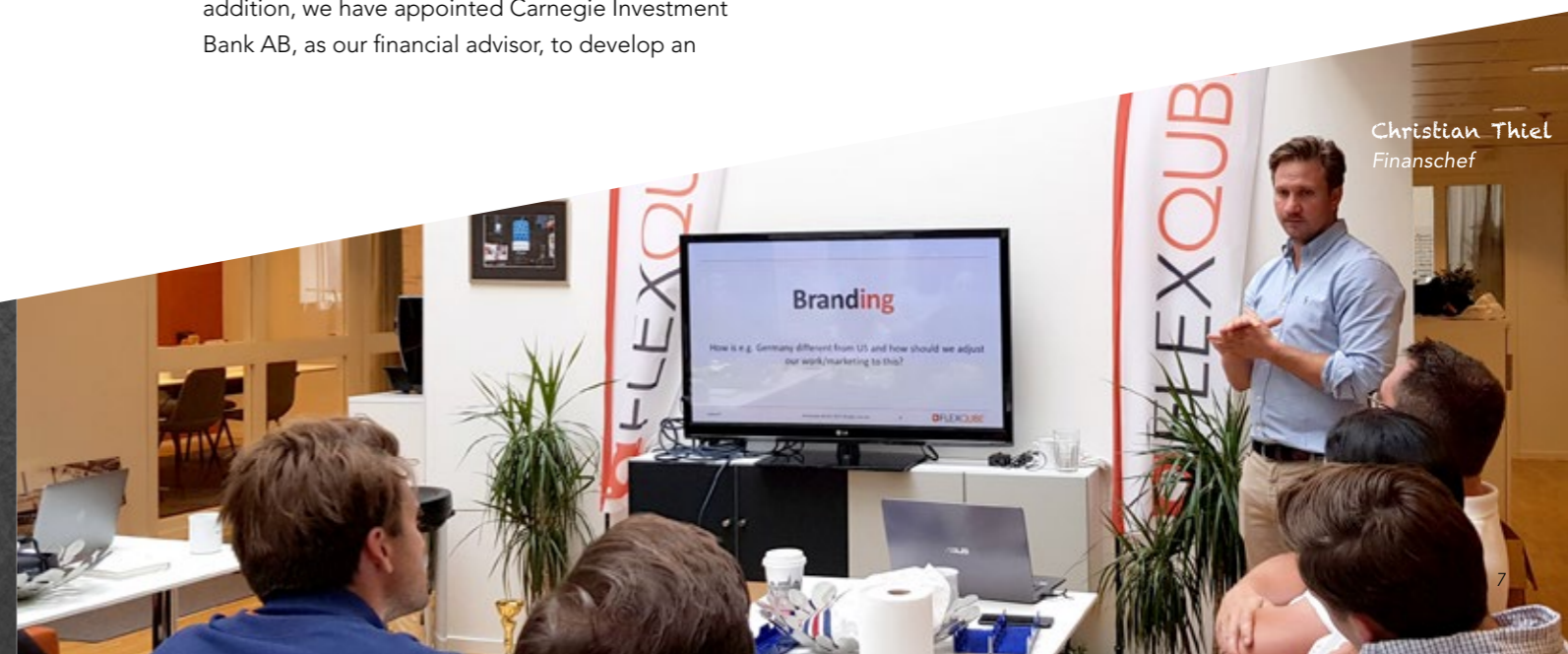

Christian Thiel  
Finanzchef



and cameras, form the basis of the modular FlexQube 4.0 concept. Desired functionality is then added to the carts using different apps and by installing software.

The ROI (return on investment) calculation for implementing SmartCarts looks very positive compared to the current automation solutions alternatives that are available to customers. It will be possible to offer the product at a lower price than traditional AGVs (Automated Guided Vehicles) found on the market, not to mention the great value of being able to reduce the number of manual transports.

“  
The market for automated logistic solutions is predicted to increase dramatically during the next few years  
”

The market for automated logistics solutions is predicted to grow dramatically during the next few years. Now that we have the ability to combine FlexQube's mechanical building blocks with digital building blocks, we have a unique market potential for offering flexible automated carts.

Alongside our traditional product range, our automated solutions will become a more prioritized area in the future. The launch will take place gradually and more properties will be added to the driverless carts in 2019. Initially, it will be possible to control the carts by remote control and drive between positions using visual steering and automatic parking.

In the future, our ambition is to strengthen the image of our products as being more environmentally beneficial than market alternatives. In discussions with our customers, we try to highlight a product life cycle perspective, as every tonne of steel that can be reused reduces carbon dioxide emissions by 1.7 tonnes. Carbon dioxide emissions can then be equated with melting icebergs, as 1 kg of carbon dioxide leads to 15 kg of melted ice caused by the global warming resulting from increased levels of carbon dioxide emissions. A clear example of this is that we were recently commissioned to quickly rebuild 80 Volvo Cars carts in the USA. Without our flexible concept, we would have likely bought completely new carts, which, in this example, would have entailed additional emissions of carbon dioxide to the scale of 7 tonnes. This would be equivalent to 100 tonnes of melting icebergs.

Considering our dramatic growth, we need to continue to put a great deal of focus on recruiting skilled employees. It is therefore positive that we have recently had several of our customers' employees express interest in starting with us, many with the argument that we have a fantastic product that they believe in and want to stand behind.

The anniversary of becoming a listed company is approaching and my colleagues and I are going to be working hard to end the year just as well as it started, so we also start 2019 on the right foot. We are on a very enjoyable and challenging journey and we are getting closer to our vision of becoming a world leader in modular intralogistic solutions.

Anders Fogelberg  
CEO of FlexQube AB (publ)



Cynthia Gutierrez  
Design Coordinator



# DEVELOPMENT DURING THE THIRD QUARTER

1 July - 30 September 2018



Numerical data given in brackets in this interim report refers to comparison with the interim period July - September 2017 or the balance sheet date 2017-09-30. FlexQube's accounting currency is Swedish kronor (SEK).

## ORDER INTAKE, REVENUE AND RESULT

The Group's order intake during the current quarter amounted to 14.4 MSEK (5.6), an increase of 158 percent compared to the same quarter last year. The group is still young and there may therefore be strong fluctuations between the quarters. The Group evaluates the accumulated order intake over several periods as more significant than individual quarters.

Net sales for the quarter amounted to 20.4 MSEK (6.2), an increase of 229 percent compared with the previous year. Total revenue increased by 196 percent and amounted to 20.7 MSEK (7.0) at the end of the period. The increase in sales is mainly attributable to growth in the North American market.

The cost of commodities that includes commodity purchases and related expenses for distribution, such as freight and packaging, amounted to 12.8 MSEK (3.6) and is due to the increased sales volume in general.

Other external expenses amounted to 2.9 MSEK (2.0). The increase of these costs has occurred in accordance with the planned expansion and is primarily

attributable to higher marketing and sales activities, increased distribution management, primarily in North America, as well as higher design and administration costs as a result of the sales development. Despite the aforementioned increases of other external costs between the comparison periods, these costs have more than halved in relation to sales growth compared to last year.

Personnel costs amounted to 5.1 MSEK (1.2). The increase between the periods relates to the planned expansion, which includes:

- Increased personnel in North America and Europe as well as related recruitment costs,
- The company has a retirement plan for all employees since the turn of the year,
- The sales staff's commission costs have followed the increased sales trend in the company, and
- Management has received remuneration that is better in line with market rates compared with the previous year.

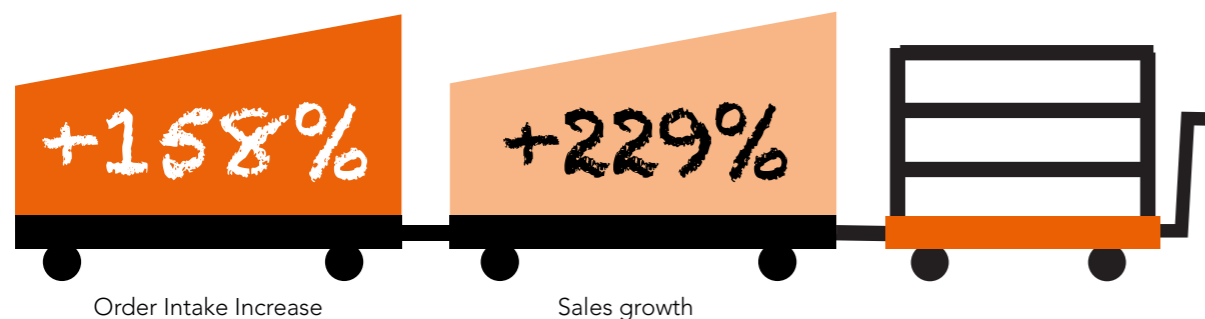

Earnings before interest, taxes, depreciation and amortization (EBITDA) amounted to -0.1 MSEK (0.2) and earnings before interest and tax (EBIT) amounted to -0.2 MSEK (0.0). Revenue before taxes amounted to -0.3 MSEK (0.0) and profit after tax amounted to -0.3 million MSEK (0.0).

For the current period, tax on earnings for the period amounted to 0.0 MSEK (0.0) due to the negative earnings for the period. Deferred tax claims on carry-backs have not been taken into account.

## CASH FLOW

Cash flow for the period amounted to -8.6 MSEK (-0.3), of which:

- Cash flow from operating activities amounted to -8.5 MSEK (-0.7) and is primarily driven by changes to inventory levels, operating receivables and operating liabilities. The change in operating receivables is attributable to growth in sales and the fact that the company chose not to finance all accounts receivable regarding invoice sales through the Group's financial credit institutions structure, due to its own acceptable liquidity. The change in operating liabilities and inventories is due to increased accounts payable and inventory levels as a result of the company's sales growth.

- Cash flow from investment activities amounted to -0.6 MSEK (-0.1), of which the majority of the sum concerns investments in tangible fixed assets linked to further development of FlexQube's concept as well as investments of lesser value in intangible assets such as patents and trademarks.

- Cash flow from financing activities amounted to 0.5 MSEK (0.6). The difference between comparison periods is attributable to the utilized share of overdraft facilities as well as planned amortization of loans. No other new loans were taken on during the current quarter.

## DEPRECIATION, WRITE-DOWNS AND INVESTMENTS

Depreciation for the period amounted to 0.2 million SEK (0.1).

The period's investments primarily refer to tangible fixed assets; including costs for office equipment and expenses linked to production improvements and development programs that are to complement FlexQube's mechanical building blocks with mechatronic building blocks. These amounted to 0.5 MSEK (0.0). Investments include intangible capital assets in the form of patents and trademarks and amounted to 0.1 MSEK (0.1).



# DEVELOPMENT DURING THE ACCUMULATED PERIOD

1 January - 30 September 2018



Numerical data given in brackets in this interim report refers to comparison with the interim period January - September 2017 or the balance sheet date 2017-09-30 FlexQube's accounting currency is Swedish kronor (SEK).

## ORDER INTAKE, REVENUE AND RESULT

The Group's order intake during the current accumulated period amounted to 50.9 MSEK (19.9), an increase of 156 percent compared to the same period last year. The group is still young and there may therefore be strong fluctuations between the quarters. The Group evaluates the accumulated order intake over several periods as more significant than individual quarters.

Net sales for the period amounted to 53.5 MSEK (22.5), an increase of 137 percent compared with the previous year. Total revenue increased by 136 percent and amounted to 54.7 MSEK (23.1) at the end of the period. The increase in sales is mainly attributable to growth in the North American market.

The cost of commodities, which includes commodity purchases and related expenses for distribution, such as freight and packaging, amounted to 32.9 MSEK (13.6) and is due to the increased sales volume in general.

Other external expenses amounted to 13.0 MSEK (7.4). The increase in these costs has gone according to planned expansion and mainly relates to:

- Several marketing and sales activities including trade shows during the current nine-month period in Germany, Netherlands, USA, Mexico and Italy, increase of demo products which are sent to customers and

in general more sales trips within Europe and North America,

- Production of new marketing materials, printing of hard copy catalogues and more marketing online,
- Increased distribution management costs, primarily in North America,
- Increased expenses for Group staff in the form of board fees and board management tools, where a new member of the board was added during the second quarter,
- Increased administrative costs for accounting and back office, as well as the purchase of new accounts and licenses for administrative IT tools due to increased staff and sales volume,
- Increased costs for the design department due to sales development,
- Stock management costs, and
- One-off start-up costs and ongoing operating costs for the German subsidiary, FlexQube GmbH.

Despite the aforementioned increase in external costs between the comparative periods, these costs fell by almost a third in relation to sales growth.

Personnel costs amounted to 13.0 MSEK (2.9). The increase between the periods relates to the planned expansion, which includes:

- Increased personnel in North America and Europe as well as related recruitment costs,
- The company has introduced a pension plan for all employees,
- The sales staff's commission costs have followed the increased sales trend in the company, and
- Management has received a market compensation in comparison with the previous year.

Earnings before interest, taxes, depreciation and amortization (EBITDA) amounted to -4.2 MSEK (-0.8) and earnings before interest and tax (EBIT) amounted to -4.7 MSEK (-1.1). Revenue before taxes amounted to -4.8 MSEK (-1.2) and profit after tax amounted to -4.8 million MSEK (-1.4).

For the current period, tax on earnings for the period amounted to 0.0 MSEK (0.1) due to the negative earnings for the period. Deferred tax claims on carry-backs have not been taken into account.

## CASH FLOW

Cash flow for the period amounted to -22.1 MSEK (0.7), of which:

- Cash flow from operating activities amounted to -21.7 MSEK (0.9), primarily driven by the change in operating receivables, operating liabilities and inventories, combined with a decrease in earnings compared to the previous year. The change in operating receivables is attributable to growth in sales and the fact that the company chose not to finance all accounts receivable regarding invoice sales through the Group's financial credit institutions structure, due to its own acceptable liquidity. The change in operating liabilities and inventories is due to increased accounts payable and inventory levels as a result of the company's sales growth.

- Cash flow from investment activities amounted to -2.0 MSEK (-0.4), of which the majority concerns investments in tangible fixed assets linked to further production and further development of FlexQube's concept as well as intangible assets such as patents and trademarks. Financial leases taken on during the previous quarter in the cash flow as part of the investment activities have been adjusted in the period's accumulated cash flow, as this item is not considered to affect the cash flow. Correspondingly, the leases have been adjusted under financing activities, and therefore do not otherwise change the cash flow.

- Cash flow from financing activities amounted to 1.6 MSEK (0.2). The difference between comparison periods is attributable to the utilized share of overdraft facilities as well as planned amortization of loans.

## DEPRECIATION, WRITE-DOWNS AND INVESTMENTS

Depreciation for the period amounted to 0.5 million SEK (0.3).

Investments for the period include intangible capital assets in the form of patents and trademarks as well as balanced expenses for development, which together amounted to 0.3 MSEK (0.4). Investments in tangible fixed assets include office equipment and service vehicles, as well as development costs related to production improvement of the current concept, a development program that will complement FlexQube's mechanical building blocks with mechatronic building components, which together amounted to 1.7 MSEK (0.0).



# FINANCIAL POSITION

*The group's balance sheet as of 30 September 2018 with comparison period 30 September 2017*

The company's total assets as of 30 September 2018 amounted to 55.6 million MSEK (14.3), of which:

Intangible capital assets amounted to 2.0 MSEK (2.0) and consist of expenses for development work on IT and software solutions for customers as well as patents and trademarks.

Tangible fixed assets amounted to 3.3 MSEK (0.3) at the end of the period, and consisted of office equipment and office inventory, development costs linked to production improvement of the current concept, as well as a development program to complement FlexQube's mechanical building blocks with mechatronic building components, and capital assets related to service vehicles that have been included in the group's balance sheet as a result of financial leasing, along with a directly owned vehicle at FlexQube GmbH.

Financial capital assets in the form of leasehold positions amounted to 0.2 MSEK (0.2) at the end of the period.

Current assets amounted to 50.1 MSEK (11.7) as of balance date, of which inventories amounted to 16.1 MSEK (4.9), accounts receivable including earned but un invoiced income amounted to 18.6 MSEK (2.4) and cash and cash equivalents amounted to 12.0 MSEK (0.8).

The increase in inventories and accounts receivable is attributable to the rise in sales and the increase of cash and cash equivalents attributable to the issue of new shares in December 2017, in connection with the company's public offering. Other short-term receivables, tax receivables and prepaid expenses and accrued income amounted to 3.4 MSEK (3.6), where the difference between the periods is attributable to prepaid accounts payable and receivables relating to value added tax.

At the end of the period, equity amounted to 31.3 MSEK (1.0). The change in equity is also attributable to the issue of new shares in December 2017 as well as in addition to received shareholders' contributions. FlexQube has appointed Carnegie Investment Bank AB as our financial advisor to develop an appropriate future capital structure.

Long-term liabilities amounted to 2.9 MSEK (5.5), this change was due to the amortization of long-term loans in 2017, and accrued liability items relating to finance leases by approximately 1.3 MSEK (0.0).

Short-term liabilities amounted to 21.4 MSEK (7.7), mainly consisting of accounts payables combined with accrued costs, which relate to the company's increased sales volume.

# CUSTOMER BASE

FlexQube's customers are found in different industry segments and regions. As of 30 September 2018 FlexQube has a customer base of approximately 346 customers in 25 different countries. The majority of these 346 customers are the result of the last two to

three years of work and the Group expects all customer accounts to develop even more positively in the coming years. Below are the segments that FlexQube operates in:

-  Manufacturing of commercial vehicles such as trucks, buses and trains
-  Manufacturing of cars
-  Subcontractors to the automobile industry
-  Manufacturing of construction and industrial machinery
-  Manufacturing of wind turbines and other energy related products
-  Manufacturing of defense equipment
-  Manufacturing of appliances and electronics
-  Storage and distribution of goods
-  Manufacturing of medical equipment

# ORDER INTAKE

Order intake increased by 158 percent during the third quarter compared with the same period in 2017, and amounted to approximately 14.4 MSEK (5.6). For the fourth quarter in a row, we show an increase in order intake of over 100 percent, and this is the result of the hard work carried out, especially since 1 January 2017. For the first nine months of 2018, order intake growth was around 156% despite the new sales organization only contributing marginally to growth. The company estimates that the new sales organization will start to have an effect in the fourth quarter 2018.

Order intake is one of FlexQube's most important metrics and something that will be communicated to the market to the extent that the Group considers a single order to be of sufficient importance for communication. Even though there is an existing customer base with very prominent customers and great potential, FlexQube is still young, and large continuous sales are not self-evident, even if they continue to grow day by day. FlexQube offers a concept where the benefits will

be greatest for the customer if implemented broadly, but where implementation is to a certain extent governed by the projects being implemented. Historically, FlexQube has not seen a customer stop buying products, but rather that their need consistently increases over time. At the same time, said need is governed by the other projects in progress with the customer, which may vary from year to year.

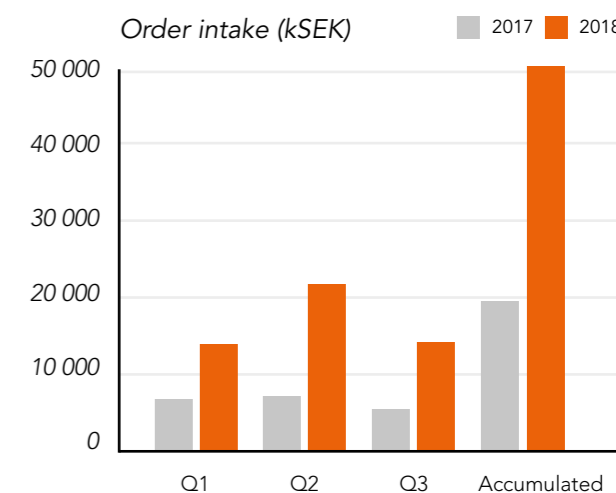



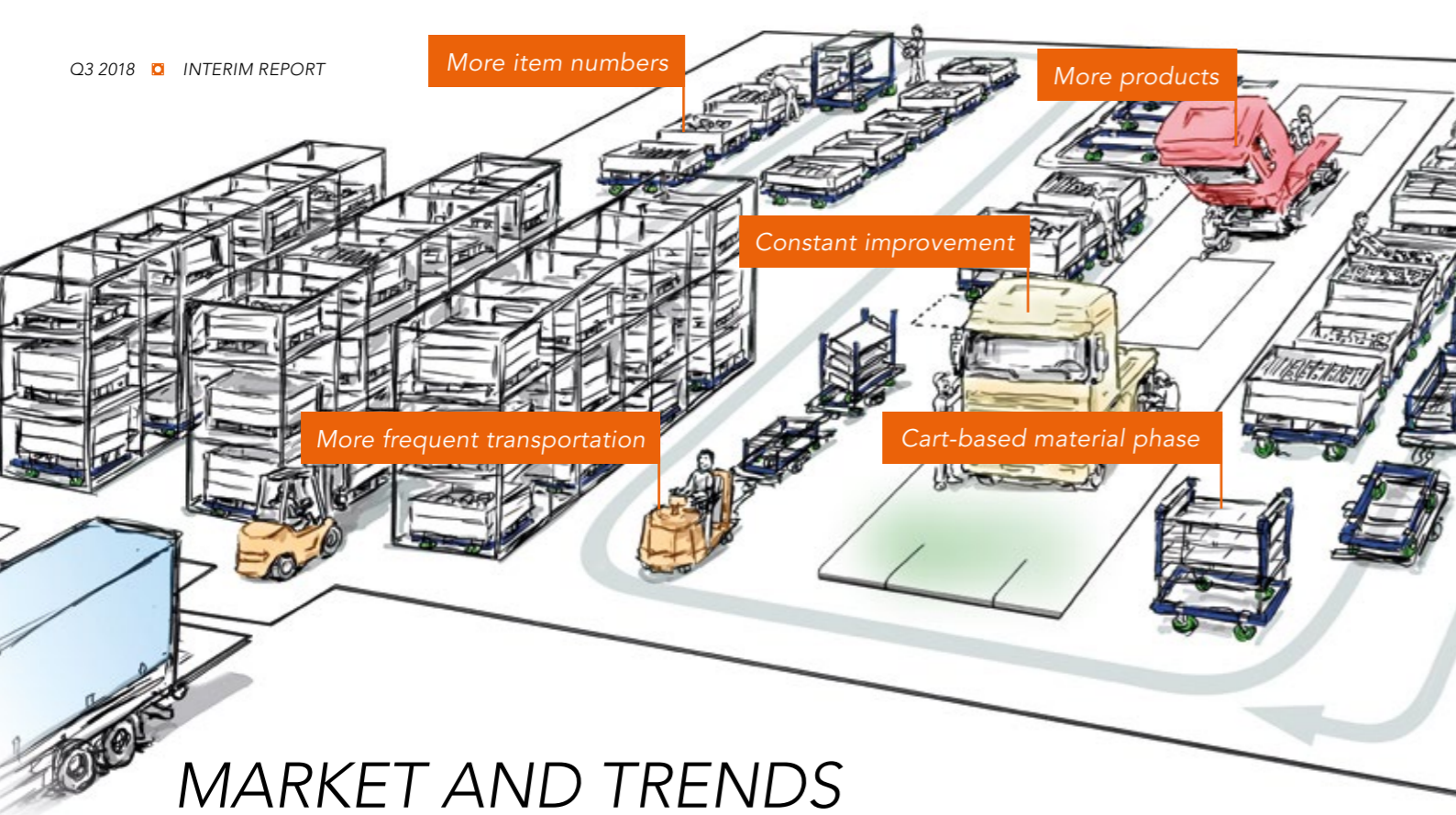

## MARKET AND TRENDS

FlexQube is a global provider of modular and robust industrial carts for material handling. The Group was founded in 2010 and ever since then has had the ambition to create a brand new market. Today, the Group has a sales organization that focuses on Europe and North America. Manufacturing takes place in Sweden for the European market and outside Atlanta in the US for the North American and Mexican markets.

The industries and segments that FlexQube operates within are undergoing major challenges in the field of material handling, where today's consumers expect more and more products and variants to choose from. The paradigm shift, called "mass customization", began in the late 1980s and has since developed into a situation where the number of products and variants offered has increased significantly.

## RISK AND UNCERTAINTIES

FlexQube is an internationally active company, which is exposed to a number of market and financial risks. Identified risks are monitored continuously, where measures to reduce the risks and their effects are taken if necessary.

Examples of financial risks are market, liquidity and credit risks. Market risks consist mainly of currency

The mass customization phenomenon drives a huge need for the products offered by FlexQube, such as the need to switch from truck-based material handling to cart-based material handling, as demands for safe and frequent transport increase. In addition to this paradigm shift, global uncertainty, rapid changes in volume and mix, as well as rapid technology development, add greater demands on flexibility and the ability to re-configure the carts.

FlexQube's goal is to help its customers improve their internal logistics and achieve this by creating unique material carts with modular building blocks, an innovative design process, and a high level of internal logistics skills.

risk. It is the Board of Directors of FlexQube that is ultimately responsible for managing and monitoring the Group's financial risks. Currency and liquidity risks represent the most significant financial risks, while interest, financing and credit risks can be considered lower risks.

Currency risk is due to the fact that some of the

Group's revenues are in EUR for the European entity, while operating expenses are mainly in SEK. The US unit has local manufacturing and supply chain in the US and only limited purchases are made from markets other than the United States. Consequently, currency risk is limited to the US unit, excluding any potential in-house transactions.

The liquidity risk is primarily due to the fact that the Group's major customers require long payment periods and that the Group is in an expansion phase. The Group is actively working to reduce these risks, where existing global financing agreements ensure a satisfactory cash flow. Liquidity risk is managed on an ongoing basis in cooperation with the Group's lenders and other financial collaborators-partners.

## CURRENCY

FlexQube's largest markets are Europe and North America. Given that the Group's reporting currency is in SEK, the Group's earnings are affected by currency translation effects on receivables and/or liabilities in USD and EUR.

## STAFF

The number of employees at FlexQube reflects the scalable business model that the Group actively works with in order to take advantage of economies of scale in the long term and, at the same time, limit the risk.

The number of employees as of 30 September 2018 was 21 (11), of whom 4 were women (1). The average number of employees during the interim period July to September 2018 was 20 (11), of whom 4 were women (1).

Although the number of employees in the company is relatively small, the company still has a wide range of expertise in relevant areas, stemming from the background, education and experience of its employees. In addition, if necessary, the company will hire staff to gain the necessary skills and to a large extent cooperate with the company's subcontractors. It can thus be pointed out that, within the company's organizational structure, the company has over 30-40 employees based with suppliers and external consultants.



## FLEXQUBE-SHARES

FlexQube's share capital amounted to 0.63 MSEK on 30 September 2018. The number of shares amounted to 6,333,333 with equal rights, corresponding to a quota value of 0.1 SEK.

The company's stock is listed on the Nasdaq Stockholm First North under the FLEXQ symbol since December 14, 2017. FlexQube had a sales volume of 431,665 shares during the period between 1 July and 30 September 2018. This resulted in an average sales volume of 6,641 shares per trading day worth 408,669 SEK. The average price of the share during the period was approximately 58.2 SEK.

FlexQube had a sales volume of 1,051,017 shares during the accumulated period between 1 January and 30 September 2018. This resulted in an average sales volume of 5,591 shares per trading day worth 265,545 SEK. The average price of the share during the period was approximately 44.1 SEK.

The last closing at the end of the period was 66 SEK, meaning an increase of 120 percent from the subscription price associated with listing it on 14 December 2017.



# ACCOUNTING PRINCIPLES

The current interim report is prepared according to ÅRL and the Swedish Accounting Board's BFNAR 2012: 1 Annual Report and Consolidated Financial Statements (K3).

Below, the most important accounting principles are described.

## CONSOLIDATED FINANCIAL STATEMENTS

Companies in which FlexQube holds the majority of votes at the Annual General Meeting are classified as subsidiaries and consolidated in the consolidated financial statements. Subsidiaries are included in the consolidated financial statements from the date on which the controlling influence is transferred to the Group. They are excluded from the consolidated financial statements from the date on which the controlling influence ceases.

The consolidated financial statements have been prepared in accordance with the acquisition method. The acquisition date is the date on which the controlling influence is obtained. Identifiable assets and liabilities are initially valued at fair value on the acquisition date. Goodwill / Negative Goodwill is the difference between the acquired identifiable net assets at the acquisition date and the acquisition value including the value of the minority interest, and is initially valued at the acquisition value. The Group has never reported any Goodwill. Negative Goodwill has arisen during an acquisition and is distributed in full before the beginning of 2015.

## DISPUTES BETWEEN GROUP COMPANIES ARE ELIMINATED IN THEIR ENTIRETY

Subsidiaries in other countries prepare their annual accounts in foreign currency. Upon consolidation, the items in these subsidiaries' balance sheets and profit bills at the closing date, with respect to the current rate for the day the respective business event took place, are calculated. The exchange rate differences arising from the calculation of the balance sheet for foreign

subsidiaries are reported in cumulative exchange rate differences in the Group's equity.

## FOREIGN CURRENCY

Monetary assets and liabilities denominated in foreign currencies are valued at the current rate of the closing day. Transactions in foreign currency are calculated at the transaction date exchange rate.

## REVENUE

Sales of goods are reported when significant risks and benefits are transferred from sellers to buyers in accordance with the terms of sale. Sales are reported after deduction of VAT and discounts. Sales of services are reported when the service in question has been carried out under the agreed terms.

## LEASE AGREEMENT

Leasing agreements that entail that the economic risks and benefits of owning an asset are essentially transferred from the lessor to the lessee are classified in the consolidated financial statements as finance leases. Financial leases entail that rights and obligations are reported as assets and liabilities in the balance sheet. The asset and liability is initially valued at the least of the asset's fair value and the present value of the minimum lease payments. Expenses directly attributable to the lease are added to the value of the asset. Leasing fees are allocated on interest and amortization according to the effective interest rate method. Variable fees are recognized as an expense in the period they arise. The leased asset is depreciated on a straight-line basis over the estimated service life.

Leases where the economic benefits and risks that are attributable to the leasehold item remain in essence with the lessor, and are classified as operational leasing. Payments, including a first increased rental, under these agreements are reported as a linear cost over the lease period.

## EMPLOYEE BENEFITS (SHORT-TERM BENEFITS)

Short-term benefits in the Group consist of salary, social security contributions, paid holiday, paid sick leave, healthcare and bonuses. Short-term benefits are reported as an expense and a liability when there is a legal or informal obligation to pay a compensation.

## COMPENSATION AFTER COMPLETION OF EMPLOYMENT

The Group holds only defined contribution plans.

In defined contribution plans, the company pays fixed fees to another company and has no legal or informal obligation to pay anything further even if the other company cannot fulfil its commitment. The Group's revenue is charged for expenses as employees' pensionable services are performed.

## INCOME TAX

Current taxes are valued based on the tax rates and tax rules applicable on the balance sheet date. Deferred taxes are valued based on the tax rates and tax rules that are determined prior to the balance sheet date.

## INTANGIBLE ASSETS

Intangible fixed assets are reported at cost less accumulated amortization and impairment losses. In terms of consolidated financial statements, the activation model for internally generated intangible assets applies.

Depreciation is carried out linearly over the estimated useful life. The amortization period for internally generated intangible capital assets amounts to five and ten years respectively.

## TANGIBLE FIXED ASSETS

Tangible fixed assets are reported to Acquisition value less depreciation. The acquisition value includes expenses directly attributable to the acquisition of the asset. Expenses for ongoing repairs and maintenance

are reported as expenses. Capital gains and losses on disposal of capital assets are reported as other operating income and other operating expenses respectively.

The following depreciation periods are applied:  
Inventories, 5 years.  
Cars, 3 years and 6 years respectively.

## FINANCIAL INSTRUMENTS

Financial instruments are reported in accordance with the rules in K3 chapter 11, which means that valuation is based on cost.

Financial instruments recognized in the balance sheet include accounts receivable and other receivables, accounts payables and loan liabilities. The instruments are reported in the balance sheet when FlexQube becomes a party to the instrument's contractual terms. Financial assets are derecognized when the right to receive cash flows from the instrument has expired or been transferred and the Group has transferred virtually all risks and benefits associated with ownership.

Financial liabilities are derecognized when liabilities have been cancelled or otherwise terminated.

## INVENTORIES

Inventories are valued at the lowest of the acquisition value and net realisable value. The acquisition value is determined using the first-in, first-out method (FIFO).

## CASH FLOW STATEMENT

The cash flow analysis is prepared according to the indirect method. The reported cash flow includes only transactions that have resulted in payments. The company classifies cash as liquid capital.

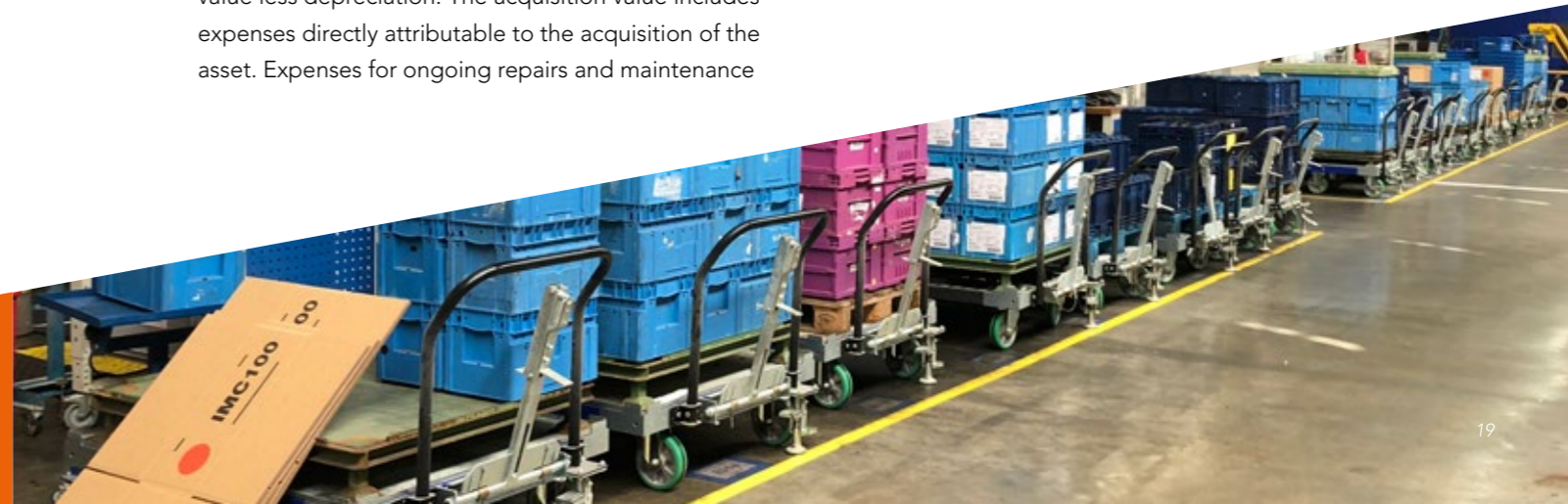



## ABOUT THE PARENT COMPANY

FlexQube AB (publ) in Gothenburg with organization number 556905-3944 is the Group's parent company. In connection with the company's public offering, the Parent Company has established a management function for the Group, within the framework of corporate management and governance. All other

business-related transactions that do not concern group management, with external and/or intra-group parties, are primarily traded by the subsidiaries, in which the parent company's development follows the development of the Group in general.

## PARENT COMPANY'S ACCOUNTING PRINCIPLES

*The same accounting and valuation principles apply in the Parent Company as in the Group, except in the cases listed below:*

### STOCKS AND SHARES IN SUBSIDIARIES

Shares and participation shares in subsidiaries are reported at cost minus any impairment losses. The acquisition value includes the purchase price paid for the shares as well as acquisition costs. Any capital contributions and group contributions are added to the acquisition value when they are submitted. Dividends from subsidiaries are reported as income.

### EQUITY

Equity is divided into bound and free capital, in accordance with the Annual Accounts Act.

## SIGNING

The Board of Directors and the Managing Director ensure that the interim report gives a true and fair view of the Parent Company and the Group's operations, position and revenue, and describes significant risks and uncertainties that the parent company and the companies included in the group face.

Gothenburg, 31 October 2018

**Ulf Ivarsson**  
Chairman of the Board

**Anders Ströby**  
Member of the Board

**Christian Thiel**  
Member of the Board

**Per Augustsson**  
Member of the Board

**Kristina Ljunggren**  
Member of the Board

**Anders Fogelberg**  
CEO





# GROUP'S KPI

Earnings	Unit	Third quarter		9 months		Whole year
		2018 Jul-Sep	2017 Jul-Sep	2018 Jan-Sep	2017 Jan-Sep	2017
Order intake*	kSEK	14,410	5,582	50,924	19,904	37,232
Net Sales	kSEK	20,419	6,209	53,466	22,535	29,004
Group's Sales Growth**	%	229%	-28%	137%	49%	51%
Operating revenue before depreciation (EBITDA)	kSEK	-56	151	-4,164	-795	-2,417
Operating revenue (EBIT)	kSEK	-242	44	-4,694	-1,114	-2,848
Operating margin	%	-1%	1%	-9%	-5%	-10%
Earnings before tax	kSEK	-286	19	-4,836	-1,225	-3,050
Profit margin	%	-1%	0%	-9%	-5%	-11%
Revenue per share before and after dilution***	SEK	0.0	0.0	-0.8	-0.3	-0.5
<b>FINANCIAL POSITION</b>						
Net debt including shareholder loans	kSEK	-25,786	1,491	-25,786	1,491	-33,451
Operating capital	kSEK	28,657	4,001	28,657	4,001	35,266
Balance liquidity	%	234%	152%	234%	152%	415%
Operating capital as a percentage of net sales	%	140%	64%	54%	18%	122%
Quick ratio including unused part of overdraft facilities	%	159%	92%	159%	92%	382%
Equity per share before and after dilution***	SEK	4.9	0.2	4.9	0.2	5.7
<b>CASH FLOW</b>						
Cash flow from operating activities	kSEK	-8,483	-724	-21,696	868	248
Cash flow from investment activities	kSEK	-628	-139	-1,996	-417	-594
Cash flow from financing activities	kSEK	541	556	1,616	210	34,242
<b>SHARES</b>						
Number of shares at the end of the period and after dilution	No.	6,333,333	5,000,000	6,333,333	5,000,000	6,333,333
Average number of shares before and after dilution***	No.	6,333,333	5,000,000	6,333,333	5,000,000	6,333,333
<b>EMPLOYEES</b>						
Average number of employees	No.	20	11	16	10	11
Number of employees at the end of the period	No.	21	11	21	11	13

## KEY DEFINITIONS

**Balance liquidity:** Current assets as a percentage of short-term liabilities.

**EBIT:** Operational revenue before interest and tax.

**EBITDA:** Operational revenue before depreciation, interest and tax.

**Equity per share:** Equity at the end of the period divided by the adjusted number of shares at the end of the accounting period.

**Sales growth:** The difference in net sales between two periods, divided by net sales during the first period.

**Cash Liquidity:** Current assets excluding inventories and including unused overdraft facilities as a percentage of short-term liabilities.

**Net Debt:** Gross debt, i.e. total long-term and short-term borrowing, including any used part of overdraft facilities, minus cash and cash equivalents, short-term receivables and easily realised assets.

**Order intake:** Value of orders received during the specified period.

**Earnings per share:** Earnings for the period in relation to the adjusted average number of shares during the accounting period.

**Operating capital:** Total current assets less short-term liabilities.

**Operating margin:** Operating revenue after depreciation as a percentage of net sales.

**Profit margin:** Revenue before tax as a percentage of net sales.

\* The order intake in foreign currency related to the interim period for 2018 is converted at the average exchange rate for the respective month in 2018, and the comparative period for 2017 is converted at the average exchange rate for the respective month in 2017. The full year 2017 has been recalculated according to the average exchange rate for the whole of 2017.

\*\* Sales growth for the period July to September 2017 and January to September 2017 is set in relation to sales for the corresponding period in 2016.

\*\*\* All periods adjusted for a new issue of shares in December 2017, a total of 6,333,333 shares.







# GROUP'S CONSOLIDATED INCOME STATEMENT

SEK	Third quarter		9 months		Whole year
	2018 Jul-Sep	2017 Jul-Sep	2018 Jan-Sep	2017 Jan-Sep	2017
Net Sales	20,418,760	6,208,580	53,465,614	22,534,520	29,004,079
Other operating revenue*	254,029	787,038	1,242,334	614,462	615,914
<b>Total operating income</b>	<b>20,672,788</b>	<b>6,995,618</b>	<b>54,707,948</b>	<b>23,148,982</b>	<b>29,619,993</b>
<b>OPERATING COSTS</b>					
Goods	-12,805,915	-3,649,171	-32,942,861	-13,567,895	-16,984,453
Other external costs	-2,867,117	-2,019,982	-12,968,171	-7,443,590	-9,989,456
Personnel costs	-5,055,759	-1,175,921	-12,961,161	-2,911,623	-4,990,081
Depreciation of capital assets	-186,168	-106,689	-529,300	-319,293	-430,658
Other operating costs*	-	-	-	-20,636	-73,335
<b>Total operating costs</b>	<b>-20,914,959</b>	<b>-6,951,762</b>	<b>-59,401,494</b>	<b>-24,263,037</b>	<b>-32,467,984</b>
Operating revenue (EBIT)	-242,171	43,855	-4,693,546	-1,114,055	-2,847,991
<b>REVENUE FROM FINANCIAL ITEMS</b>					
Other interest income and similar income items	-	-	-	47	534
Operating costs and similar income items	-44,323	-24,672	-142,529	-110,728	-202,383
<b>Total financial items</b>	<b>-44,323</b>	<b>-24,672</b>	<b>-142,529</b>	<b>-110,681</b>	<b>-201,849</b>
Earnings after financial items	-286,494	19,184	-4,836,074	-1,224,736	-3,049,840
Tax on period earnings	-1,772	-81	-12,920	-138,749	-523
<b>EARNINGS FOR THE YEAR</b>	<b>-288,265</b>	<b>19,102</b>	<b>-4,848,994</b>	<b>-1,363,485</b>	<b>-3,050,363</b>
<b>APPLICABLE TO:</b>	<b>-288,265</b>	<b>19,102</b>	<b>-4,848,994</b>	<b>-1,363,485</b>	<b>-3,050,363</b>
Parent company owner	-	-	-	-	-
Earnings per share applicable to parent company owner**	0.0	0.0	-0.8	-0.2	-0.5

\* Contains exchange rate changes of operating items.

\*\* Adjusted for a new issue of shares in December 2017, a total of 6,333,333 shares.



# GROUP BALANCE SHEET

## Assets

SEK	2018-09-30	2017-09-30	2017-12-31
<b>ASSETS</b>			
<b>Capital assets</b>			
<b>Intangible capital assets</b>			
Balanced expenses for development work and similar work	553,876	703,640	676,891
Concessions, patents, licences, trademarks	1,418,155	1,274,089	1,326,822
<b>Total intangible capital assets</b>	<b>1,972,031</b>	<b>1,977,729</b>	<b>2,003,713</b>
<b>Tangible fixed assets</b>			
Machinery and other technical assets	1,622,575	-	-
Inventories, tools and facilities	1,683,790	301,925	341,500
<b>Total tangible capital assets</b>	<b>3,306,365</b>	<b>301,925</b>	<b>341,500</b>
<b>Financial assets</b>			
Other long-term receivables	243,750	243,750	243,750
<b>Total financial capital assets</b>	<b>243,750</b>	<b>243,750</b>	<b>243,750</b>
<b>Total capital assets</b>	<b>5,522,146</b>	<b>2,523,404</b>	<b>2,588,963</b>
<b>Current assets</b>			
Finished goods and goods for sale	16,088,843	4,938,238	6,035,635
<b>Total inventories, etc.</b>	<b>16,088,843</b>	<b>4,938,238</b>	<b>6,035,635</b>
<b>Short-term receivables</b>			
Accounts receivable	18,244,856	2,351,061	3,017,940
Current tax receivables	68,980	45,176	37,939
Other receivables	1,180,682	3,243,031	530,337
Accumulated but un invoiced revenue	336,881	-	-
Prepaid costs and accrued expenses	2,145,400	336,866	2,770,436
<b>Total short-term receivables</b>	<b>21,976,800</b>	<b>5,976,134</b>	<b>6,356,651</b>
Cash and bank balances	12,037,014	824,739	34,059,241
<b>Total current assets</b>	<b>50,102,657</b>	<b>11,739,110</b>	<b>46,451,527</b>
<b>TOTAL ASSETS</b>	<b>55,624,803</b>	<b>14,262,513</b>	<b>49,040,490</b>

# GROUP BALANCE SHEET

## Equity and debt

SEK	2018-09-30	2017-09-30	2017-12-31
<b>EQUITY*</b>			
<b>Total equity</b>	<b>31,308,494</b>	<b>1,032,008</b>	<b>36,039,985</b>
<b>LONG-TERM LIABILITIES</b>			
Liabilities to credit institutions	920,000	1,242,500	1,115,000
*Other long-term liabilities**	1,951,136	4,250,000	700,000
<b>Total long-term liabilities</b>	<b>2,871,136</b>	<b>5,492,500</b>	<b>1,815,000</b>
<b>SHORT-TERM LIABILITIES</b>			
Liabilities to credit institutions	360,000	510,000	510,000
Accounts payable	15,839,045	3,612,467	6,361,257
Overdraft facilities***	2,176,642	1,950,459	-
Current tax liabilities	11,314	140,142	9,827
Other short-term liabilities	100,000	667,367	352,512
Accrued expenses and prepaid income	2,958,171	857,570	3,951,908
<b>Total short-term liabilities</b>	<b>21,445,173</b>	<b>7,738,005</b>	<b>11,185,504</b>
<b>TOTAL EQUITY AND LIABILITIES</b>	<b>55,624,803</b>	<b>14,262,513</b>	<b>49,040,490</b>

\* The distribution of shareholders' equity is shown in the consolidated report on changes in shareholders' equity on the next page.

\*\* Other long-term liabilities also include loans from owners and related parties.

\*\*\* Specification of the overdraft limit and unused part of the overdraft facility for the respective period is given below:

	2018-09-30	2017-09-30	2017-12-31
Overdraft limit (SEK)	2,300,000	2,300,000	2,300,000
Unused part of the overdraft facility (SEK)	123,358	349,541	2,300,000



## GROUP'S CHANGES IN EQUITY

SEK	Share capital	Other paid-up capital	Other equity		Total equity
			Accumulated currency difference	Balanced earnings	
Opening balance 01/01/2017	50,000	1,803,000	-99,069	-1,336,887	417,044
<b>Earnings for the year</b>				<b>-3,050,363</b>	<b>-3,050,363</b>
Exchange rate differences when calculating foreign subsidiaries			13,643		13,643
Obtained shareholder contribution		1,900,000			1,900,000
Issue of bonus shares	450,000	-450,000			0
New issue of shares	133,333	36,626,329			36,759,662
<b>CLOSING BALANCE 31/12/2017</b>	<b>633,333</b>	<b>39,879,329</b>	<b>-85,426</b>	<b>-4,387,250</b>	<b>36,039,985</b>
Opening Balance 01/01/2018	633,333	39,879,329	-85,426	-4,387,250	36,039,985
<b>Earnings for the year</b>				<b>-4,848,994</b>	<b>-4,848,994</b>
Exchange rate differences when calculating foreign subsidiaries			117,503		117,503
<b>CLOSING BALANCE 30/09/2018</b>	<b>633,333</b>	<b>39,879,329</b>	<b>32,077</b>	<b>-9,236,244</b>	<b>31,308,494</b>

\* Liquidity for new issues is offset for listing costs amounting to approximately 3.2 MSEK.

## GROUP'S CASH FLOW STATEMENT

SEK	Third quarter		9 months		Whole year
	2018 Jul-Sep	2017 Jul-Sep	2018 Jan-Sep	2017 Jan-Sep	2017
<b>ONGOING ACTIVITIES</b>					
Operating revenue before financial items	-242,171	43,855	-4,693,546	-1,114,055	-2,847,991
Adjustments for items that are not included in the cash flow					
Depreciation	186,168	106,689	529,300	319,293	430,658
Other items that are not included in the cash flow	-274,945	81,690	64,064	78,449	13,643
Interest obtained	-	-	-	47	534
Interest paid	-44,323	-24,672	-142,529	-110,728	-202,383
Paid income tax	-40,595	-7,731	-42,474	-49,059	-33,911
<b>Cash flow from operating activities before changes in working capital</b>	<b>-415,866</b>	<b>199,831</b>	<b>-4,285,184</b>	<b>-876,053</b>	<b>-2,639,450</b>
<i>Cash flow from changes in operating capital</i>					
Changes in inventories	-2,973,279	-90,267	-10,053,208	1,130,796	33,398
Changes in operating receivables	-9,081,276	-752,764	-15,589,108	198,647	-3,189,107
Changes in operating liabilities	3,987,574	-80,965	8,231,539	414,594	6,042,867
<b>Cash flow from operating activities</b>	<b>-8,482,847</b>	<b>-724,165</b>	<b>-21,695,960</b>	<b>867,985</b>	<b>247,708</b>
<b>INVESTMENT ACTIVITIES</b>					
Acquisition of intangible capital assets	-106,673	-125,019	-253,925	-375,057	-491,300
Acquisition of tangible fixed assets	-521,004	-14,020	-1,742,180	-42,061	-102,742
<b>Cash flow from investment activities</b>	<b>-627,677</b>	<b>-139,039</b>	<b>-1,996,105</b>	<b>-417,118</b>	<b>-594,042</b>
<b>FINANCING ACTIVITIES</b>					
New issue	-	-	-	-	36,759,662
Change in overdraft credit	711,582	193,445	2,176,642	42,343	-1,908,116
Borrowings	-	500,000	-	500,000	3,500,000
Amortization of loans	-170,785	-137,500	-560,399	-332,500	-4,110,000
<b>Cash flow from financing activities</b>	<b>540,797</b>	<b>555,945</b>	<b>1,616,243</b>	<b>209,843</b>	<b>34,241,546</b>
<b>CASH FLOW FOR THE PERIOD</b>	<b>-8,569,727</b>	<b>-307,259</b>	<b>-22,075,822</b>	<b>660,710</b>	<b>33,895,212</b>
Liquid capital at the beginning of the period	20,648,539	1,131,996	34,059,241	164,028	164,028
Exchange rate difference in cash	-41,798	-	53,595	-	-
<b>LIQUID CAPITAL AT THE END OF THE PERIOD</b>	<b>12,037,014</b>	<b>824,739</b>	<b>12,037,014</b>	<b>824,739</b>	<b>34,059,241</b>



# PARENT COMPANY'S CONSOLIDATED INCOME STATEMENT

SEK	Third quarter		9 months		Whole year
	2018 Jul-Sep	2017 Jul-Sep	2018 Jan-Sep	2017 Jan-Sep	2017
Net Sales	154,195	-	458,370	-	127,373
Other operating income	-	-	257,210	-	-
<b>Total operating income</b>	<b>154,195</b>	<b>0</b>	<b>715,580</b>	<b>0</b>	<b>127,373</b>
<b>OPERATING COSTS</b>					
Other external costs	-301,755	-	-927,956	-	-192,310
Other operating costs	-258,640	-	-	-	-17,928
<b>Total operating costs</b>	<b>-560,395</b>	<b>0</b>	<b>-927,956</b>	<b>0</b>	<b>-210,238</b>
Operating revenue (EBIT)	-406,200	0	-212,376	0	-82,865
<b>REVENUE FROM FINANCIAL ITEMS</b>					
Other interest income and similar income items	79,265	-	233,627	-	4,225
Operating costs and similar income items	-	-	-	-	-2,250
<b>Total financial items</b>	<b>79,265</b>	<b>0</b>	<b>233,627</b>	<b>0</b>	<b>1,976</b>
Earnings after financial items	-326,935	0	21,251	0	-80,889
Tax on period earnings	-	-	-	-	-
<b>EARNINGS FOR THE YEAR</b>	<b>-326,935</b>	<b>0</b>	<b>21,251</b>	<b>0</b>	<b>-80,889</b>

# PARENT COMPANY'S BALANCE SHEET

SEK	2018-09-30	2017-09-30	2017-12-31
<b>ASSETS</b>			
<b>Capital assets</b>			
<b>Financial assets</b>			
Shares in group companies	8,835,194	3,766,072	8,585,805
Receivables from Group companies	27,553,586	-	14,517,359
<b>Total financial capital assets</b>	<b>36,388,780</b>	<b>3,766,072</b>	<b>23,103,164</b>
<b>Total capital assets</b>	<b>36,388,780</b>	<b>3,766,072</b>	<b>23,103,164</b>
<b>Current assets</b>			
<b>Short-term receivables</b>			
Receivables from Group companies	451,094	-	143,295
Other receivables	540,191	-	217,580
Prepaid costs and accrued expenses	267,758	-	4,225
<b>Total short-term receivables</b>	<b>1,259,043</b>	<b>0</b>	<b>365,100</b>
Cash and bank balances	3,118,807	302	19,924,944
<b>Total current assets</b>	<b>4,377,851</b>	<b>302</b>	<b>20,290,044</b>
<b>TOTAL ASSETS</b>	<b>40,766,631</b>	<b>3,766,374</b>	<b>43,393,208</b>
<b>EQUITY</b>			
Total equity	40,290,326	3,590,302	40,269,075
<b>LONG-TERM LIABILITIES</b>			
Liabilities to group companies	-	176,072	-
<b>Total long-term liabilities</b>	<b>0</b>	<b>176,072</b>	<b>0</b>
<b>SHORT-TERM LIABILITIES</b>			
Accounts payable	65,175	-	631,258
Other short-term liabilities	6,513	-	-
Accrued expenses and prepaid income	404,618	-	2,492,875
<b>Total short-term liabilities</b>	<b>476,305</b>	<b>0</b>	<b>3,124,134</b>
<b>TOTAL EQUITY AND LIABILITIES</b>	<b>40,766,631</b>	<b>3,766,374</b>	<b>43,393,208</b>



# FINANCIAL CALENDAR

FlexQube's financial reports are available on the company's website. The following reports are scheduled to be published as follows:

■ Quarterly report 4, 2018	2019-02-15
■ Annual Report 2018	2019-04-04
■ Quarterly report 1, 2019	2019-05-03
■ AGM 2019	2019-05-03
■ Quarterly report 2, 2019	2019-08-09
■ Quarterly report 3, 2019	2019-11-01
■ Quarterly report 4, 2019	2020-02-21



## CONTACT INFORMATION

**FlexQube AB (publ)**  
556905-3944  
Kungsgatan 28  
411 19 Gothenburg, Sweden

Investor Relations  
[ir@flexqube.com](mailto:ir@flexqube.com)  
+4672-711-1477  
[www.flexqube.com](http://www.flexqube.com)





[www.flexqube.com](http://www.flexqube.com)  
#flexqube  
[www.twitter.com/flexqube](https://www.twitter.com/flexqube)  
[www.linkedin.com/company/flexqube-ab/](https://www.linkedin.com/company/flexqube-ab/)  
[www.youtube.com/user/FlexQube](https://www.youtube.com/user/FlexQube)  
[www.facebook.com/FlexQube](https://www.facebook.com/FlexQube)  
[www.instagram.com/flexqube/](https://www.instagram.com/flexqube/)